



Ali CMB Project

—— An Introduction to **AliCPT**

(**Ali CMB Polarization Telescope**)

Xinmin Zhang

Institute of High Energy Physics

Chinese Academy of Sciences

On behalf of AliCPT collaboration

Dec. 18th, 2019 @ “B mode from space” , MPA, Munich

Outline of the talk

- AliCPT site
- B mode physics (from space ⊕ ground)
- AliCPT collaboration
- AliCPT current status, future plan and science
- Summary

Where is the AliCPT (Ali CMB Polarization Telescope)

Located on a hilltop B1 ($32^{\circ}18'38''$ N, $80^{\circ}01'50''$ E),

in the Ngari (Ali) Prefecture of Tibet,

at an altitude of **5250 meters**.



- The Himalayas is to its southwest and runs from northwest to southeast, separating the Ngari(Ali) prefecture from the Indian Ocean.



- AliCPT (B1, 5250m) is only about **1km** to the current well-developed A1 station (5100m) of the Ali astronomical observatory.

How to go to AliCPT



- Ngari Gunsa Airport is about 20 km away from the AliCPT site.
- Daily commercial flight between Ngari and Lhasa
One flight between Ngari and Kashgar (Xinjiang Uyghur Autonomous Region) every Tuesday and Friday.

- The National Highway No. 219 from Airport to the Shiquanhe city;
- A road branched off to the AliCPT station at B1.



China National Highway G219



- Concrete pavement towards the B1 point has been completed.

Shiquanhe City



Shiquanhe City

- Capital of Ali prefecture
- Population around 20,000,
- Equipped with culture, commerce and health facilities.



120 Emergency Center



Hotel (with Oxygen Provided)



Post office



It is only 30 km away from the AliCPT site.

A1 station

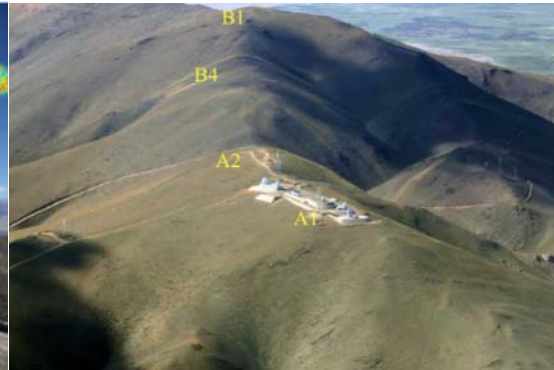
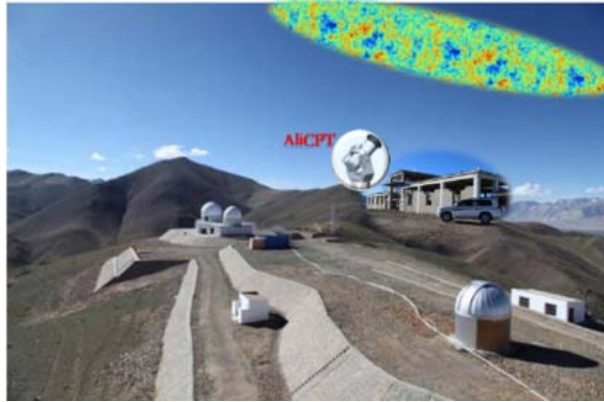

Developed about 10 years ago
150m lower than
B1 (AliCPT)
About 1km away from B1

- Some optical telescopes are running now.

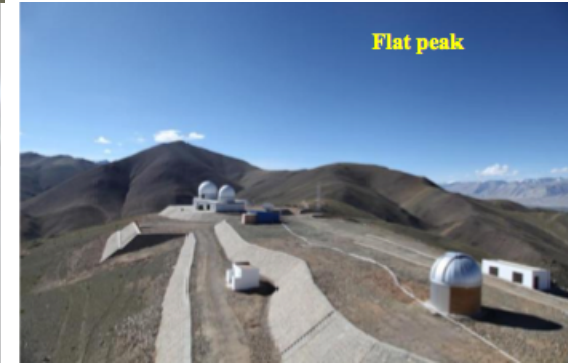

- City grid **electric power** and the **network** connection have been set up.

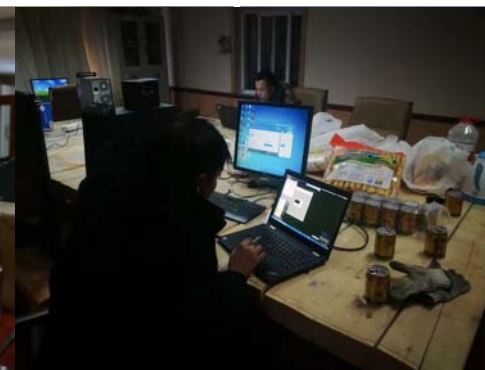

B1 station (AliCPT site)



Altitude: 5250m

Coord : 32°18'38" N 80°01'50" E

Figure left:

Construction began in Mar. 2017



Building 850m²

Weather station:

Pressure, wind speed/direction, temperature

City grid electric power / Generator

Network connection

Oxygen system

Wind break





Ali: open up a new window for CMB polarization observations

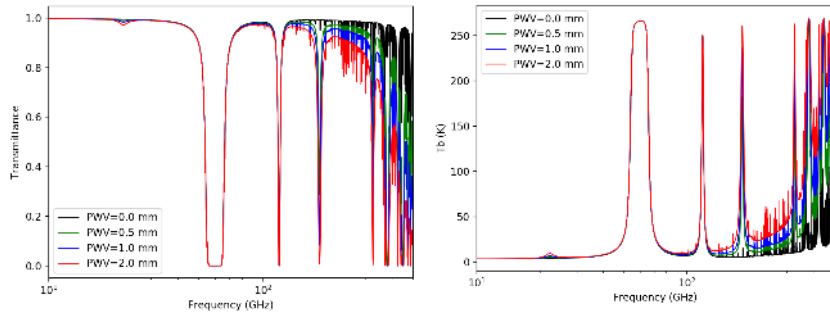

Water vapor will:

- Reduce transmittance (absorption)
- Increase photon shot noise (emission)
- Increase optical loading on detectors (emission)

Greenland

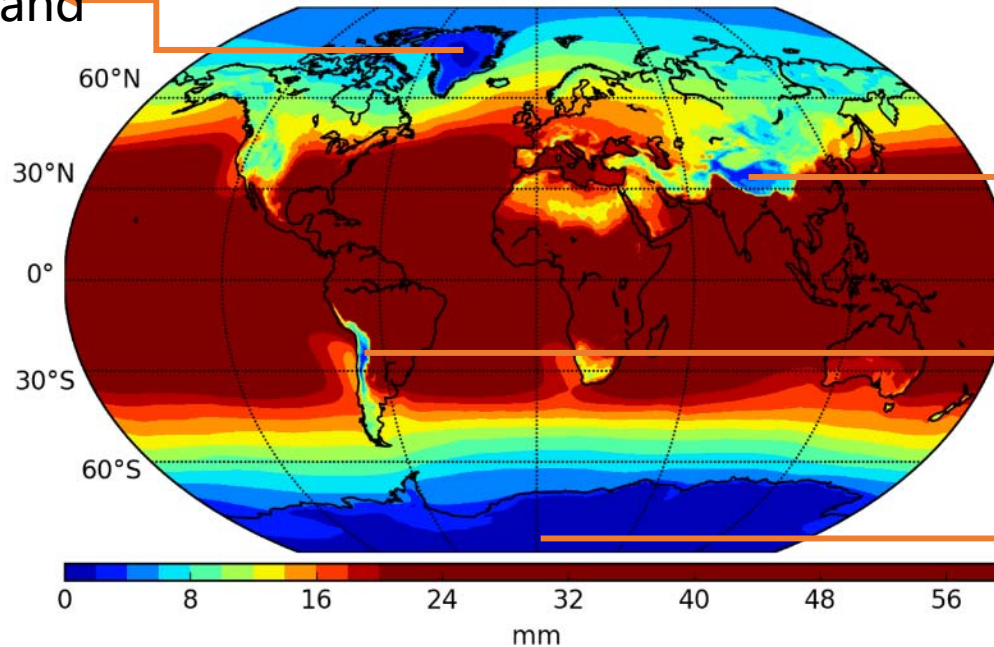

Tibet

Atacama

Antarctic



POLARBEAR
ACTPoI



e.g. SPT and BICEP



H. Li *et al* [arXiv:1710.03047](https://arxiv.org/abs/1710.03047),

Kuo C.-L.: [arXiv:1707.08400](https://arxiv.org/abs/1707.08400)

Global distribution of mean PWV (Precipitable Water Vapor)

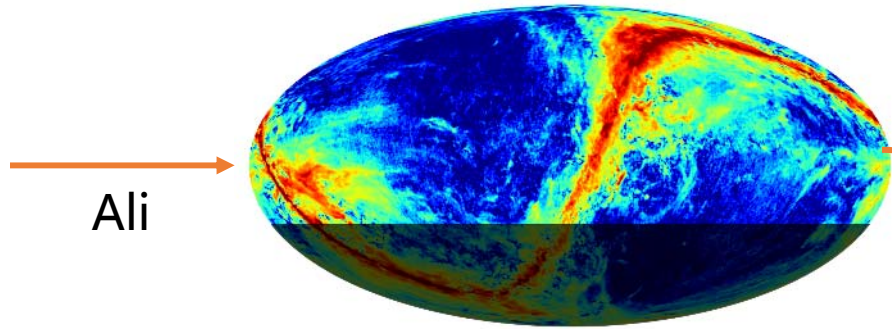

Ali

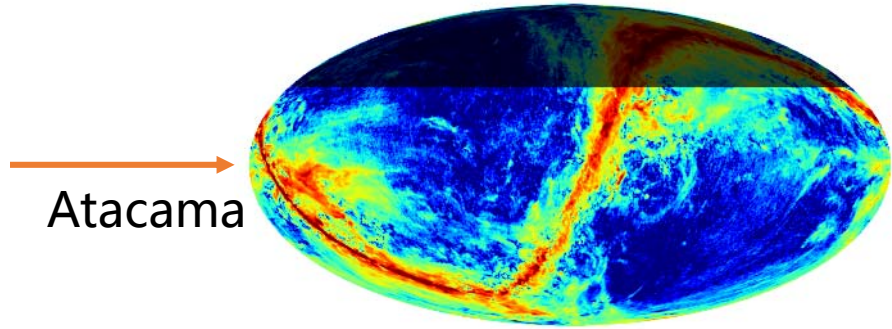

Atacama

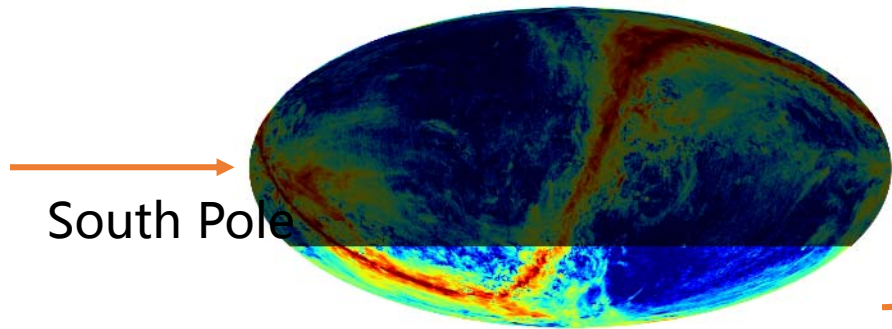

South Pole

- AliCPT can cover
 - whole northern sky and partial southern sky
 - region with the lowest foreground contamination in the north.

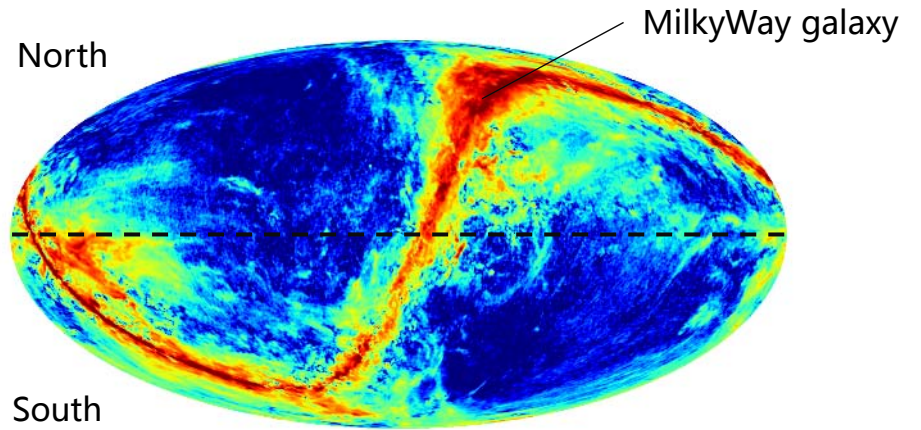

North

MilkyWay galaxy

South

- Overlap between AliCPT and southern experiments can be used for cross-check.
- Complementary to missions in Antarctic and Atacama. Realize full sky coverage.

South Pole, Atacama Desert, Ali → Full sky coverage

CMB polarization: E/B mode

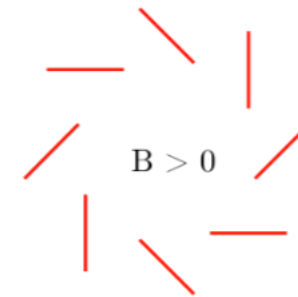
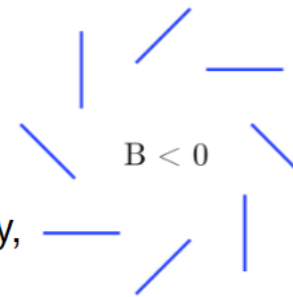
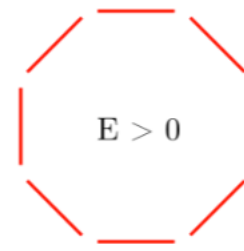
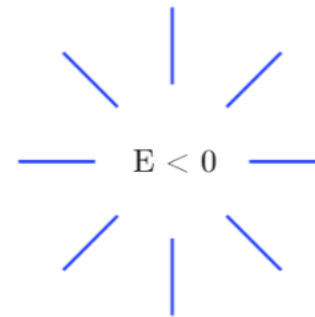
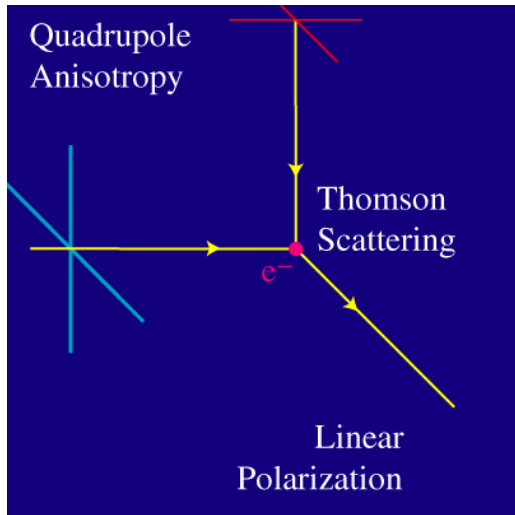

Scalar quadrupole, azimuthal symmetric generates T and E

Tensor quadrupole, without azimuthal symmetry, generates T, E and **B**

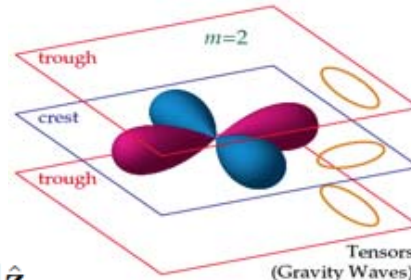
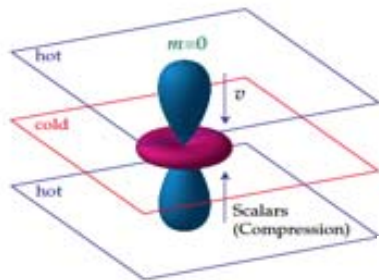

Wayne hu

- E mode: even Parity
- B mode: odd Parity

The physics of the B mode

Observations:

CMB polarization maps

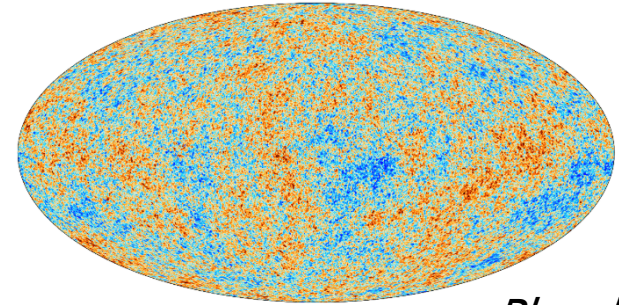

Planck

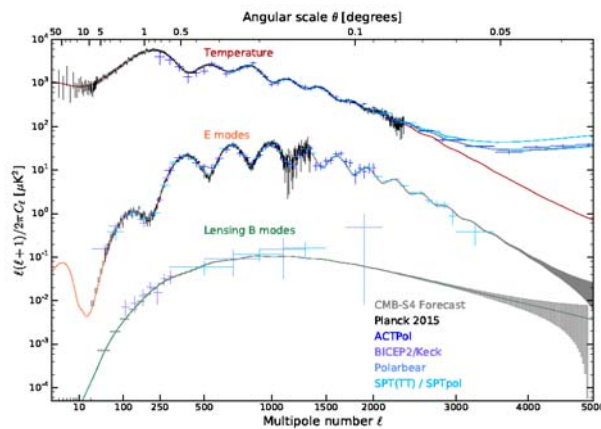

CMB-S4, arxiv: 1610.02743

$$\begin{matrix} C_{\ell}^{BB} \\ C_{\ell}^{TB} \\ C_{\ell}^{EB} \end{matrix}$$

Estimate

Constrain

$$\begin{matrix} r \\ \alpha \equiv \bar{\alpha} + \delta\alpha \end{matrix}$$

Phenomenological parameters:

- r : tensor to scalar ratio
- $\bar{\alpha}$: global CMB rotation angle
- $\delta\alpha$: spatial dependent rotation angle

Dynamical models for $r, \bar{\alpha}, \delta\alpha$

- r : Inflation theory
introducing $\phi(x)$, then inflaton

$$\mathcal{L} \sim \frac{1}{2} \partial_\mu \phi \partial^\mu \phi - V(\phi)$$

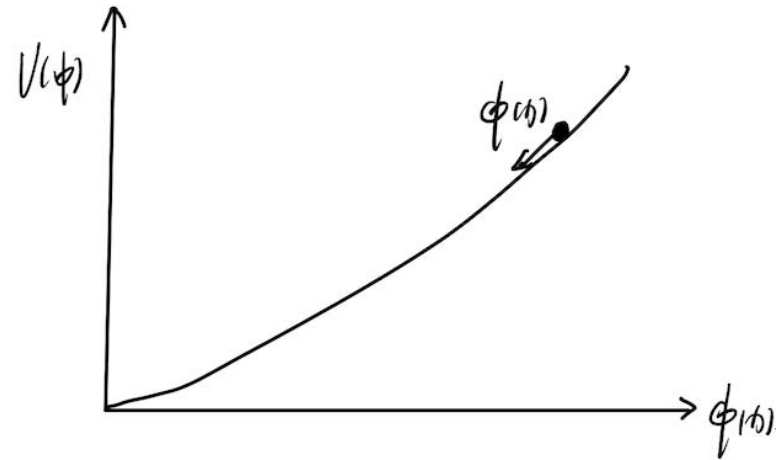

- α : Chern-Simons theory

$$\mathcal{L}_{QED} \sim -\frac{1}{4} \mathcal{F}_{\mu\nu} \mathcal{F}^{\mu\nu} + \frac{c}{M} \phi(x) \mathcal{F}_{\mu\nu} \tilde{\mathcal{F}}^{\mu\nu}$$

where: $\tilde{\mathcal{F}}^{\mu\nu} = \frac{1}{2} \epsilon^{\mu\nu\alpha\beta} \mathcal{F}_{\alpha\beta}$

$\phi(x)$: Axion scalar,

Axion string,

Quintessence scalar

$$V(\phi) \sim m^2 \phi^2, \lambda \phi^4, \dots$$

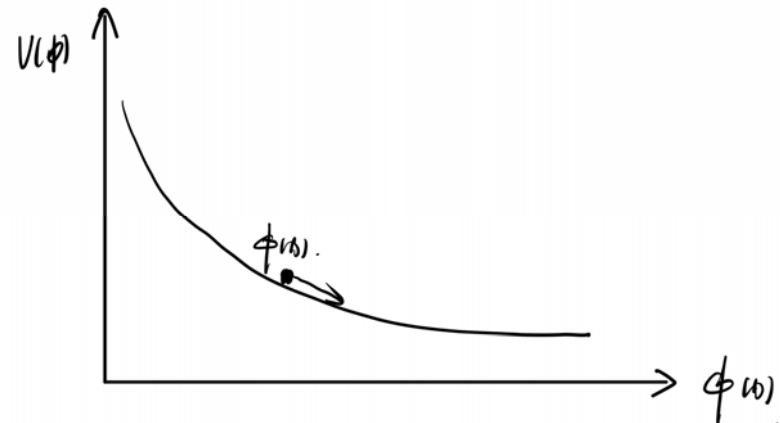

Chern-Simons theory (Axion coupling)

$$\phi(x)\mathcal{F}_{\mu\nu}\tilde{\mathcal{F}}^{\mu\nu} \sim \phi(x)\partial_\mu K^\mu \longrightarrow \partial_\mu(\phi(x)K^\mu) - \partial_\mu\phi K^\mu$$

$$K^\mu \sim \epsilon^{\mu\nu\alpha\beta} A_\nu \mathcal{F}_{\alpha\beta}, \quad \int \partial_\mu(\phi(x)K^\mu) = 0 \quad (\text{Trivial vacuum})$$



$$\phi(x)\mathcal{F}_{\mu\nu}\tilde{\mathcal{F}}^{\mu\nu} \longrightarrow -\partial_\mu\phi(x)K^\mu$$

During $\phi(x)$ evolution

$$\partial_\mu \phi(x) \longrightarrow \langle \partial_0 \phi(x) \rangle$$

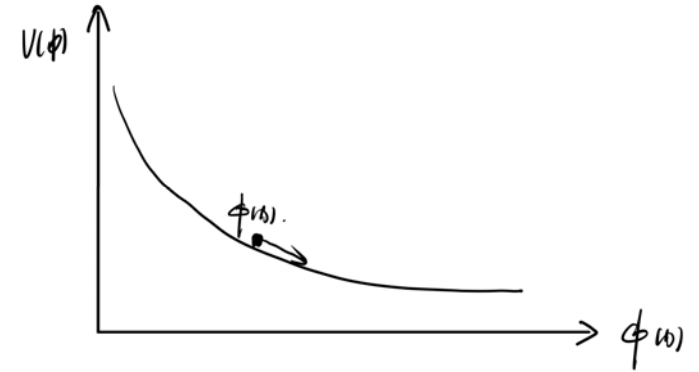

For RW universe, time dependent vacuum expectation.

$$\partial_\mu \phi(x) K^\mu \longrightarrow \langle \partial_0 \phi(x) \rangle K^0$$

Under CPT transformation:

$$\langle \partial_\mu \phi(x) \rangle K^\mu \xrightarrow{\text{CPT}} -\langle \partial_\mu \phi(x) \rangle K^\mu$$

So now:

$$\mathcal{L}_{QED} \sim -\frac{1}{4} \mathcal{F}_{\mu\nu} \mathcal{F}^{\mu\nu} + P_\mu A_\mu \tilde{\mathcal{F}}^{\mu\nu}$$

P_μ : P_0 constant (explicit CPT violation)

$$\partial_\mu \phi(x) \longrightarrow \langle \partial_0 \phi(x) \rangle \text{ (cosmologically)}$$

$$\partial_\mu f(R) \text{ (R: Ricci scalar)}$$

With the Chern-Simons term, the CMB polarization get rotated

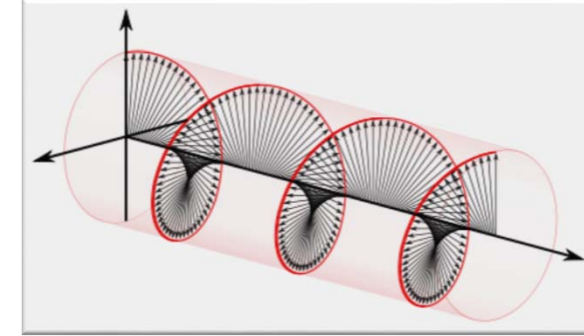

$$Q^r \pm iU^r = e^{\pm 2i\bar{\alpha}}(Q \pm iU)$$

Rotation angle: $\alpha = - \int_i^f dx^\mu p_\mu$, $p_\mu \sim - \partial_\mu \phi$

$$C_\ell^{EE,r} = C_\ell^{EE} \cos^2(2\bar{\alpha}) + C_\ell^{BB} \sin^2(2\bar{\alpha})$$

$$C_\ell^{TE,r} = C_\ell^{TE} \cos(2\bar{\alpha})$$

$$C_\ell^{BB,r} = C_\ell^{EE} \sin^2(2\bar{\alpha}) + C_\ell^{BB} \cos^2(2\bar{\alpha})$$

$$C_\ell^{TB,r} = C_\ell^{TE} \sin(2\bar{\alpha})$$

$$C_\ell^{EB,r} = \frac{1}{2}(C_\ell^{EE} - C_\ell^{BB}) \sin(4\bar{\alpha}) ,$$

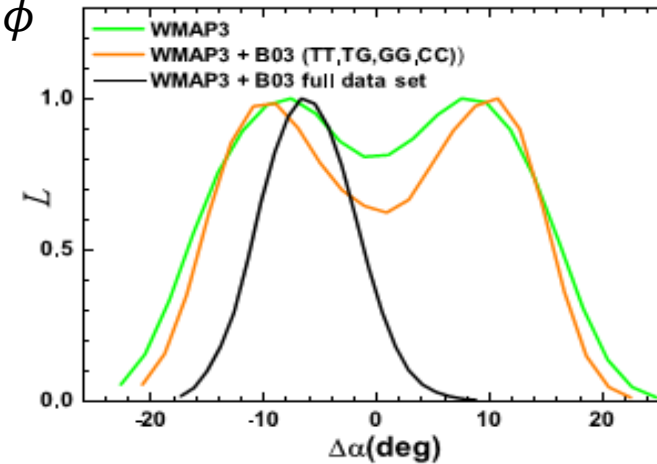

*Bo Feng, Mingzhe Li, Jun-Qing Xia,
Xuelei Chen and Xinmin Zhang
Phys. Rev. Lett. 96, 221302 (2006)*

Measurements on $\bar{\alpha}$ from CMB experiments

Reference/Data	Rotation angle $\bar{\alpha}$
¹ WMAP3+BO3	$-6^\circ \pm 4^\circ$
² WMAP3	$-2.5^\circ \pm 3.0^\circ$
³ WMAP5	$-1.7^\circ \pm 2.1^\circ$
⁴ WMAP7	$-1.1^\circ \pm 1.4^\circ \pm 1.5^\circ$
⁵ WMAP9	$-0.36^\circ \pm 1.24^\circ \pm 1.5^\circ$
⁶ QUaD	$-0.56^\circ \pm 0.82^\circ \pm 0.5^\circ$
⁷ BICEP1	$-2.60^\circ \pm 1.02^\circ$
⁸ BICEP1	$-2.77^\circ \pm 0.86^\circ \pm 1.3^\circ$
⁹ POLARBEAR	$-1.08^\circ \pm 0.20^\circ \pm 0.5^\circ$
¹⁰ ACTPol	$-0.2^\circ \pm 0.5^\circ$
¹¹ Planck 2015	$0.35^\circ \pm 0.05^\circ \pm 0.28^\circ$

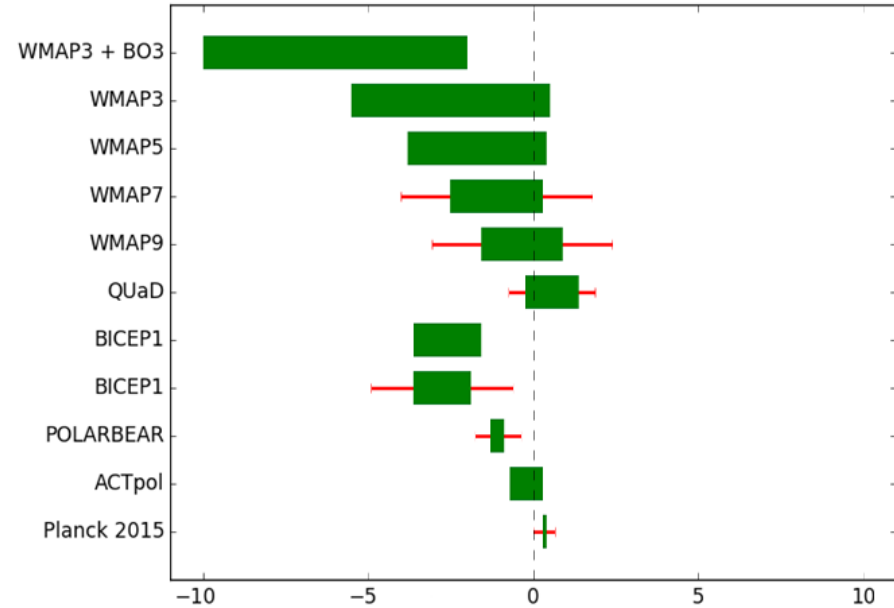

¹Feng, et.al., 2006, PRL 96, 221302

²Cabella, et.al., J. 2007, PRD, 76, 123014

³Komatsu, et.al., 2009, ApJS, 180, 330-376

⁴Komatsu, et.al., 2011, ApJS, 192, 18

⁵Hinshaw, et.al., 2013, ApJS, 208, 19

⁶QUaD Collaboration, et.al., 2009, PRL, 102, 161302

⁷XIA, et.al., 2010, PLB 687, 129

⁸BICEP1 Collaboration, et.al., 2014, PRD, 89,062006

⁹The POLARBEAR Collaboration, et.al., 2014, ApJ, 794, 171

¹⁰Naess, et.al., 2014, JCAP, 10, 007

¹¹Planck Collaboration, arXiv:1605.08633

Cosmological *CPT* violating effect on CMB polarization

Mingzhe Li^{1,2,3} and Xinmin Zhang⁴

e-Print: [arXiv:0810.0403](https://arxiv.org/abs/0810.0403)

¹*Fakultät für Physik, Universität Bielefeld, D-33615 Bielefeld, Germany*

²*Department of Physics, Nanjing University, Nanjing 210093, People's Republic of China*

³*Joint Center for Particle, Nuclear Physics and Cosmology, Nanjing University–Purple Mountain Observatory, Nanjing 210093, People's Republic of China*

⁴*Institute of High Energy Physics, Chinese Academy of Sciences, P.O. Box 918-4, Beijing 100049, People's Republic of China*

(Received 15 October 2008; published 14 November 2008)

A dark energy scalar (or a function of the Ricci scalar) coupled with the derivative to the matter fields will violate the *CPT* symmetry during the expansion of the Universe. This type of cosmological *CPT* violation helps to generate the baryon number asymmetry and gives rise to the rotation of the photon polarization which can be measured in the astrophysical and cosmological observations, especially the experiments of the cosmic microwave background radiation. In this paper, we derive the rotation angle in a fully general relativistic way and present the rotation formulas used for the cosmic microwave background data analysis. Our formulas include the corrections from the **spatial fluctuations** of the scalar field. We also estimate the magnitude of these corrections in a class of dynamical dark energy models for quintessential baryo/leptogenesis.

DOI: 10.1103/PhysRevD.78.103516

PACS numbers: 98.80.Cq, 98.70.Vc, 98.80.Es

$$\begin{aligned}
 C_l^{EE} + C_l^{BB} &= \exp[-4C^\alpha(0)] \sum_{l'} \frac{2l' + 1}{4\pi} (C_{l'}^{EE} + C_{l'}^{BB}) \int_{-1}^1 d_{22}^{l'}(\beta) d_{22}^l(\beta) e^{4C^\alpha(\beta)} d\cos(\beta) \\
 C_l^{EE} - C_l^{BB} &= \cos(4\bar{\alpha}) \exp[-4C^\alpha(0)] \sum_{l'} \frac{2l' + 1}{4\pi} (C_{l'}^{EE} - C_{l'}^{BB}) \int_{-1}^1 d_{-22}^{l'}(\beta) d_{-22}^l(\beta) e^{-4C^\alpha(\beta)} d\cos(\beta) \\
 C_l^{EB} &= \sin(4\bar{\alpha}) \exp[-4C^\alpha(0)] \sum_{l'} \frac{2l' + 1}{4\pi} (C_{l'}^{EE} - C_{l'}^{BB}) \int_{-1}^1 d_{-22}^{l'}(\beta) d_{-22}^l(\beta) e^{-4C^\alpha(\beta)} d\cos(\beta) \\
 C_l^{TE} &= C_l^{TE} \cos(2\bar{\alpha}) e^{-2C^\alpha(0)} \\
 C_l^{TB} &= C_l^{TE} \sin(2\bar{\alpha}) e^{-2C^\alpha(0)}
 \end{aligned}$$

M. Li, B. Yu
arXiv:1303.1881

How to Derotate the Cosmic Microwave Background Polarization

Marc Kamionkowski

e-Print: [arXiv:0810.1286](https://arxiv.org/abs/0810.1286) [

California Institute of Technology, Mail Code 130-33, Pasadena, California 91125, USA

(Received 7 October 2008; revised manuscript received 12 February 2009; published 19 March 2009)

If the linear polarization of the cosmic microwave background is rotated in a frequency-independent manner as it propagates from the surface of last scatter, it may introduce a B -mode polarization. Here I show that measurement of higher-order TE , EE , EB , and TB correlations induced by this rotation can be used to reconstruct the rotation angle as a function of position on the sky. This technique can be used to distinguish primordial B modes from those induced by rotation. The effects of rotation can be distinguished geometrically from similar effects due to cosmic shear.

DOI: [10.1103/PhysRevLett.102.111302](https://doi.org/10.1103/PhysRevLett.102.111302)

PACS numbers: 98.70.Vc

list of references on anisotropy of rotation angle:

- POLARBEAR Collaboration 1509.02461
- BICEP/Keck Collaboration 1705.02523
- Amit P.S. Yadav, Rahul Biswas, Meng Su, Matias Zaldarriaga 0902.4466
- Vera Gluscevic, Marc Kamionkowski, Asantha Cooray 0905.1687
- Vera Gluscevic, Duncan Hanson, Marc Kamionkowski, Christopher M. Hirata 1206.5546
- Carlo Cotaldi 1510.02629
- Toshiya Namikawa 1612.07855
- Dylan R. Sutton, Chang Feng, Christian L. Reichardt 1702.01871
- Dagoberto Contreras, Paula Boubel, Douglas Scott 1705.06387
- Levon Pogolian, Meir Shimon, Matthew Mewes, Brian Keating 1904.07855
- ...

$(r, \bar{\alpha}, \delta\alpha)$ strongly correlated

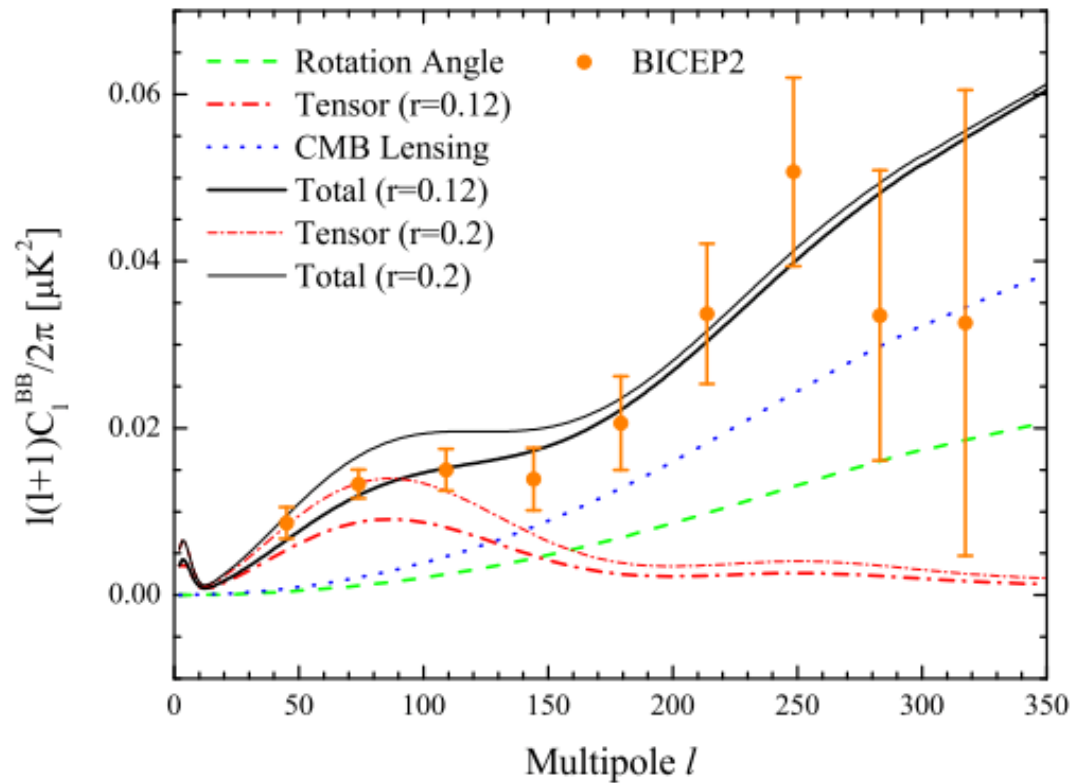
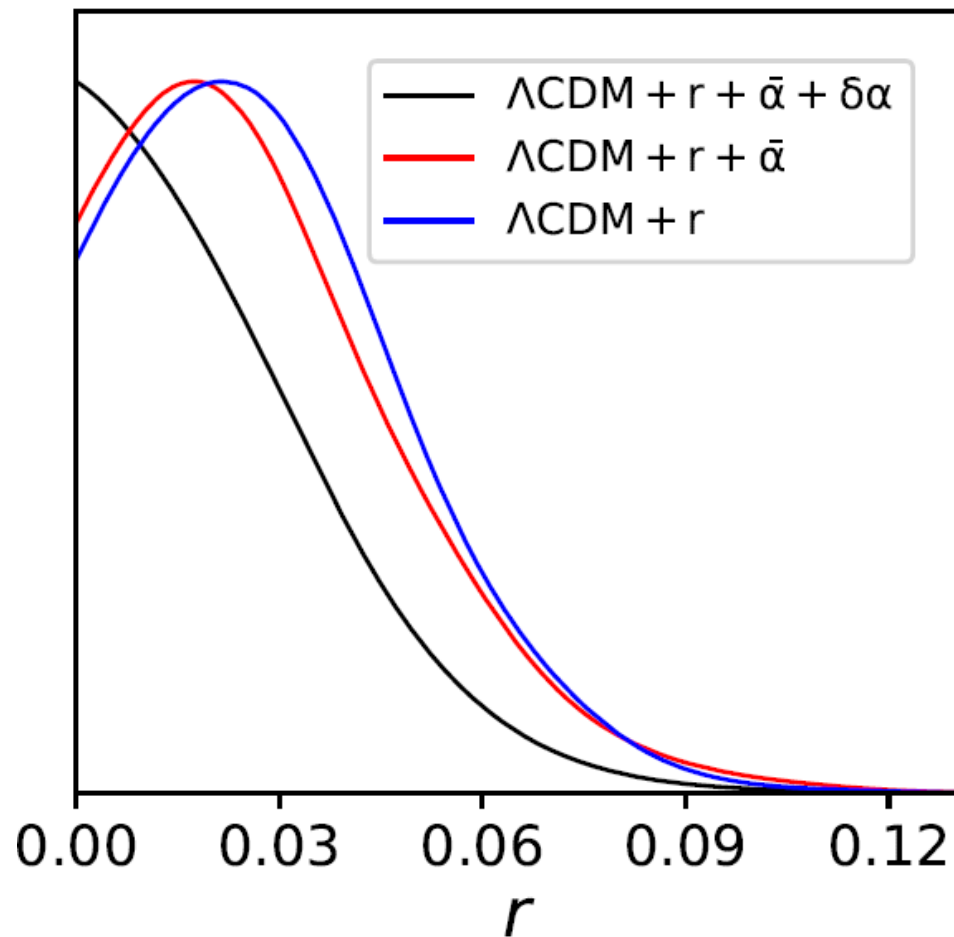

FIG. 3.— Theoretical CMB power spectra (thick lines) for the best fit model obtained from the WMAP9+B03+BICEP2 data combination. The red thin line denotes the contribution of tensor perturbations with $r = 0.2$, and the black thin line is the total CMB BB power spectrum correspondingly. For comparison, we also show the BICEP2 observational data.

**Joint constraint on “B mode physics parameters” ($r, \bar{\alpha}, \delta\alpha$)
with CMB polarization data
from BICEP, Planck, ACT, SPT, POLARBEAR**



H. Zhai, S. Li, M. Li, Xinmin Zhang, [arXiv: 1910.02395](https://arxiv.org/abs/1910.02395)

AliCPT-1 collaboration

- Led by the IHEP, the international collaboration includes: about 100 scientists from China, US, Europe.
- Funded already by the CAS, NSF of China.
- Executive board: Xinmin Zhang (PI), Chao-Lin Kuo (US PI), Fang-jun Lu (Manager)



Core member institutes of AliCPT-1 collaboration

- IHEP: Pipeline, data analysis, scan strategy, control system, site, mount, test/integration
- Stanford: Cryostat receiver, optics/AR, focal plane module
- NAOC: Logistics, site
- NIST: Detector arrays and modules, feedhorns and readout components
- ASU: LNAs, cryogenic harness, readout electronics
- NTU: Scan strategy, calibration
- APC: Science, data analysis
- USTC: E/B leakage, early universe models
- SJTU: Foregrounds, cross-correlations
- BNU: Foregrounds, lensing
- ...



AliCPT-1 current status, future plan (AliCPT-2) and science

AliCPT-1 Timeline & AliCPT-2

- 2014 – Project proposed
- 2017 – Site construction starts
- 2018 – Site construction ends
- 2019 – Cryostat under fab,
design single pixel detector,
mount under test,
pipeline development
- 2019 – cryostat delivery at Stanford ,
- 2020 – Integration, test, commissioning at Stanford

Deployment and first light with at least one and up to 4 modules by end of 2020

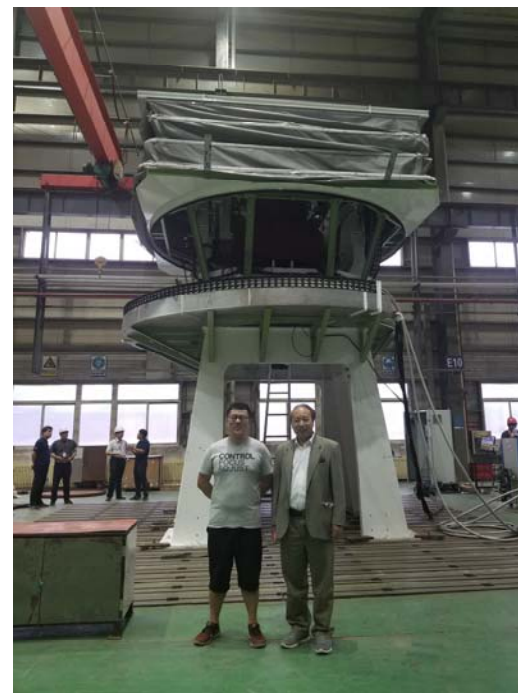

AliCPT-2:

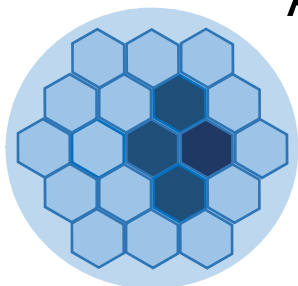

- Add 15 modules to AliCPT-1 (with more frequencies?)
2020 4 modules, 2021 10 modules, 2022 15 modules,
2023 19 modules
- Large aperture Telescopes

Mount



Sept. 2019

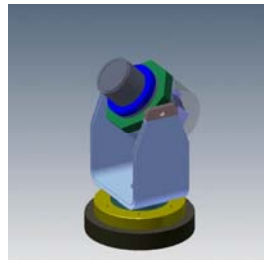

1. Bearing capacity

➤ max. 1.5tons



2. Driver spec. requirements

➤ AZ: range ± 270 deg. angular speed > 5 deg/sec

➤ EL: range 45-135deg. angular speed > 1 deg/sec

➤ DK: range 0-181deg. angular speed > 2 deg/sec



3. Pointing accuracy

➤ better than 1' w/o correction

➤ Better than 10" w/ pointing model correction



Test now, and expect to ship to B1-site soon.

Slides from Congzhan Liu

AliCPT-1 in a nutshell

- 72cm aperture, FOV 20.8° (4-7det tiles)
FOV 33.4° (19det tiles)
- 95/150GHz, 27/19% bandwidth
- 19' and 11'
- 1704 pol-sensitive, optical dichroich TESes per tile
- 280mK, NEP 3-5~10⁻¹⁷W/sqrt(Hz)
- 4 detector modules
- Cryostat and optics: up to 19 det modules
- Forebaffle design: up to 7 det modules
- scanning in azimuth at constant elevation
- (45°-70°) elevation range
- up to 4°/s scanning speed
- Instrument design heritage BICEP3

Ahmed Z. et al., SPIE 2014

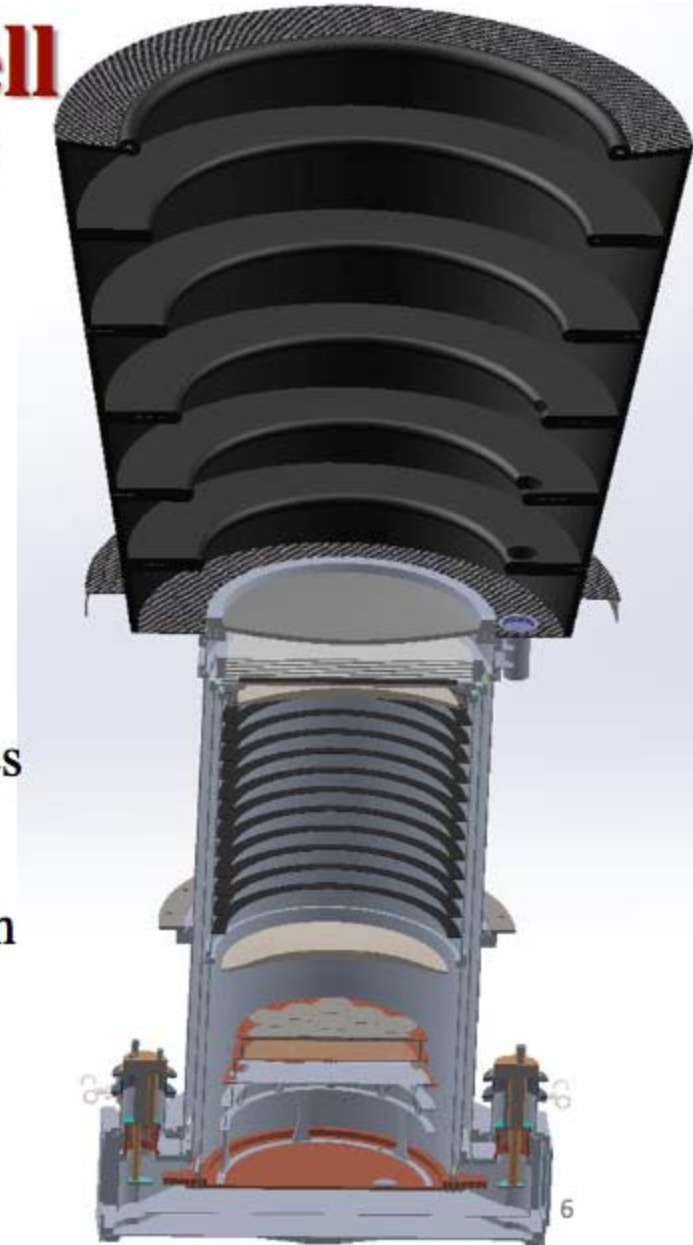

Slides from Maria Salatino

Cryostat Receiver Overview

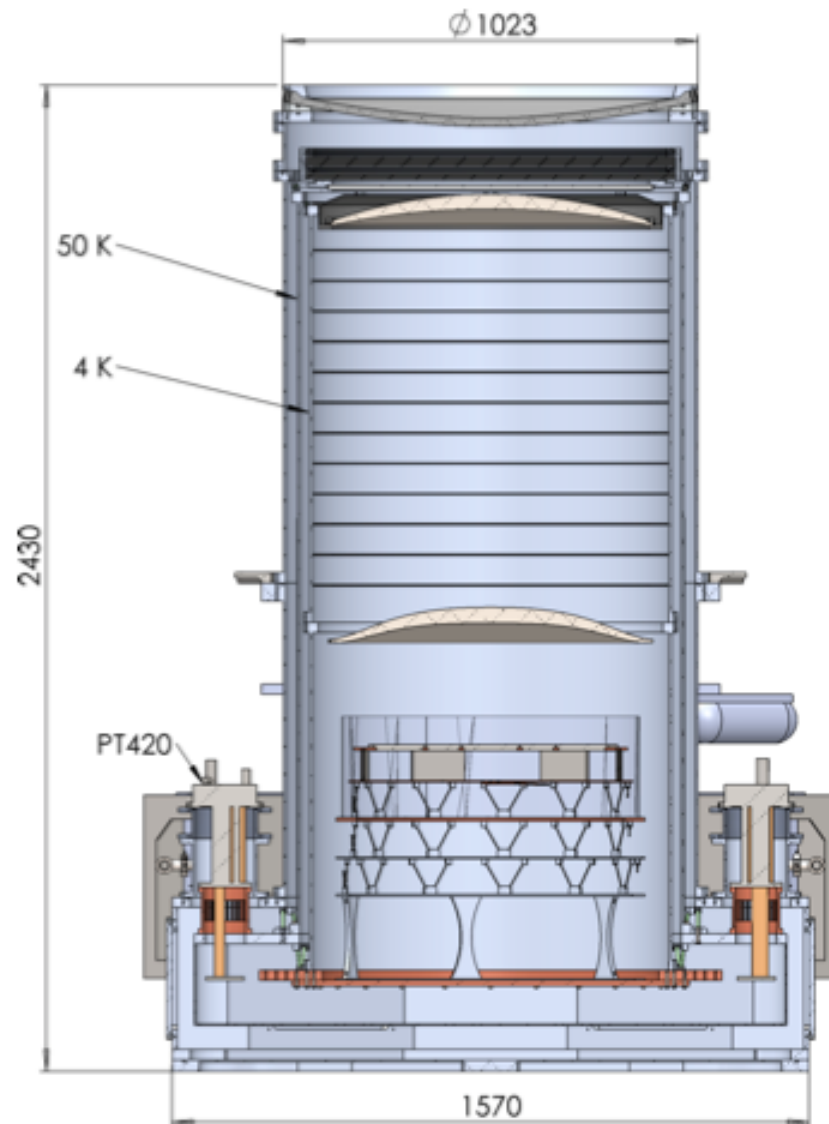

Mechanics

- 300K, 50K, 4K tubes/baserings
- G-10CR structures

Window

IR Filters

- Zotefoam layers
- 50K Alumina/Nylon filters

Cold Optics

- 4K Alumina lenses/AR epoxy mix

Cryogenics

- 1/2x PT-420
- Custom GL10 absorption fridge

TESes array and μ mux

14

AliCPT sciences

B mode physics:

- **BB:** Measuring the primordial gravitational waves (PGWs), tensor to scalar ratio (r), probing the origin of the universe.
- **TB, EB, BB:** Measuring the rotation angle ($\bar{\alpha}, \delta\alpha$), testing CPT symmetry.
- Investigating the CMB polarization hemispherical asymmetry.
- Studying the cross-correlation between AliCPT and DESI.
- Cosmology with precision measurement of CMB E modes.
- Studying the galactic foreground.
- Studying the dark energy property, neutrino masses

◦ ◦ ◦ ◦ ◦ ◦

Sensitivity

Sensitivity on map level:

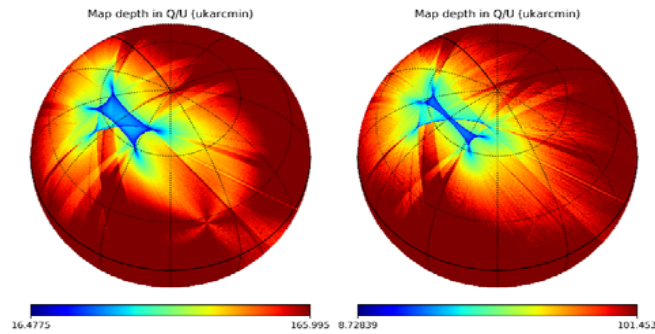

PLANCK 100 GHz & 143 GHz
Pol ~50 uKarcmin in total

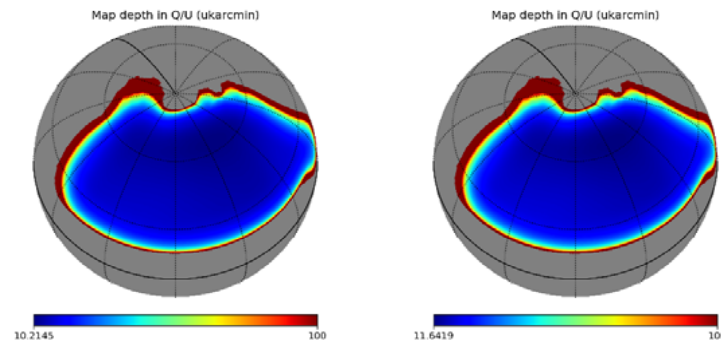

AliCPT 4 modules 1 season
Median map-depth 14 uKarcmin

Sensitivity on r and $\bar{\alpha}$:

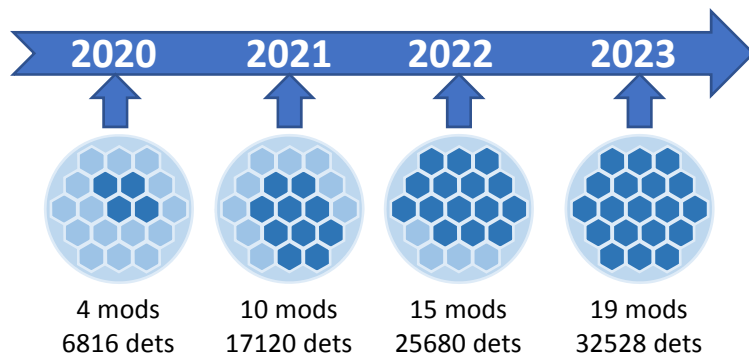

according to PI's plan, AliCPT-1 for the first years' observation, AliCPT-1 + 2 for 2021-2023.

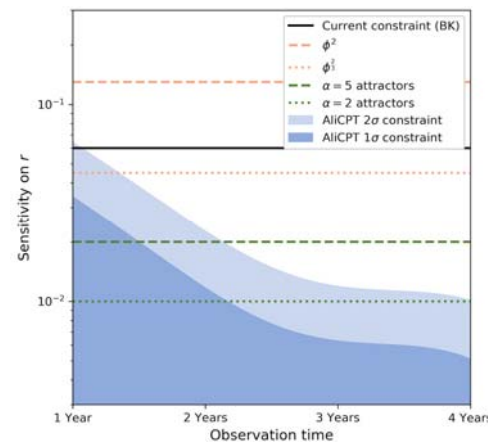

Raw sensitivity on r

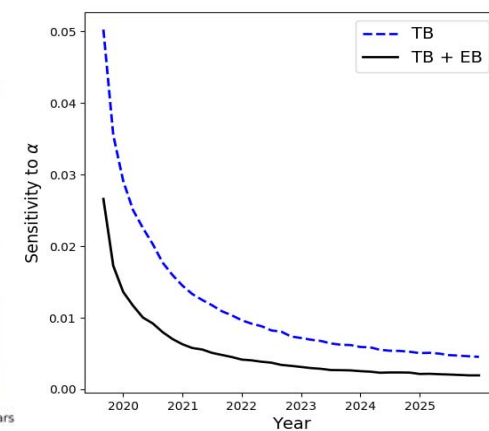

Raw sensitivity on $\bar{\alpha}$ 30

Summary

AliCPT is one of the four gravitational waves projects in China (for the PGWs); The others being FAST, space probes TianQin & TaiJi (for the astrophysical GWs).

- AliCPT-1: First light in 2020.
- AliCPT-2: More detectors, more frequencies, larger aperture.
- Complimentary to SO in Atacama desert, BICEP Array in South Pole... for sky coverage, science (testing inflation theory, Chern-Simons theory, CPT symmetry...).

Thanks!